

POW-R-QUIK

Starter Part Number: 6-HS-108V RHX

Hydraulic Starter Specifications:	
Engine Application	Various Gas & Diesel Engines
Hydraulic Oil, Supply Pressure	Max. = 3000 psi (207 bar)
Hydraulic Oil, Flow Required @3000 psi	6-7 GPM (23-26 LPM)
Hydraulic Oil, Specification	Normal operating viscosity range: 80-1000 SUS (16-220 cSt) Maximum startup viscosity should not exceed 4000 SUS (864 cSt)
Max Starter Torque Output at 3000psi (207 BAR)	21.3 ft-lbs (28.9 Nm)
Operating Temperatures	-40°C to 82°C (-40°F to 180°F)
Flange Characteristics	Engine Dependent
Pinion Characteristics	Engine Dependent
Weight	30 lbs (13.6 kg)

$$\text{Pinion speed} = \text{engine speed} * \frac{\text{ring gear tooth count}}{\text{pinion tooth count}}$$

$$\text{Engine torque} = \text{starter torque} * \frac{\text{ring gear tooth count}}{\text{pinion tooth count}}$$

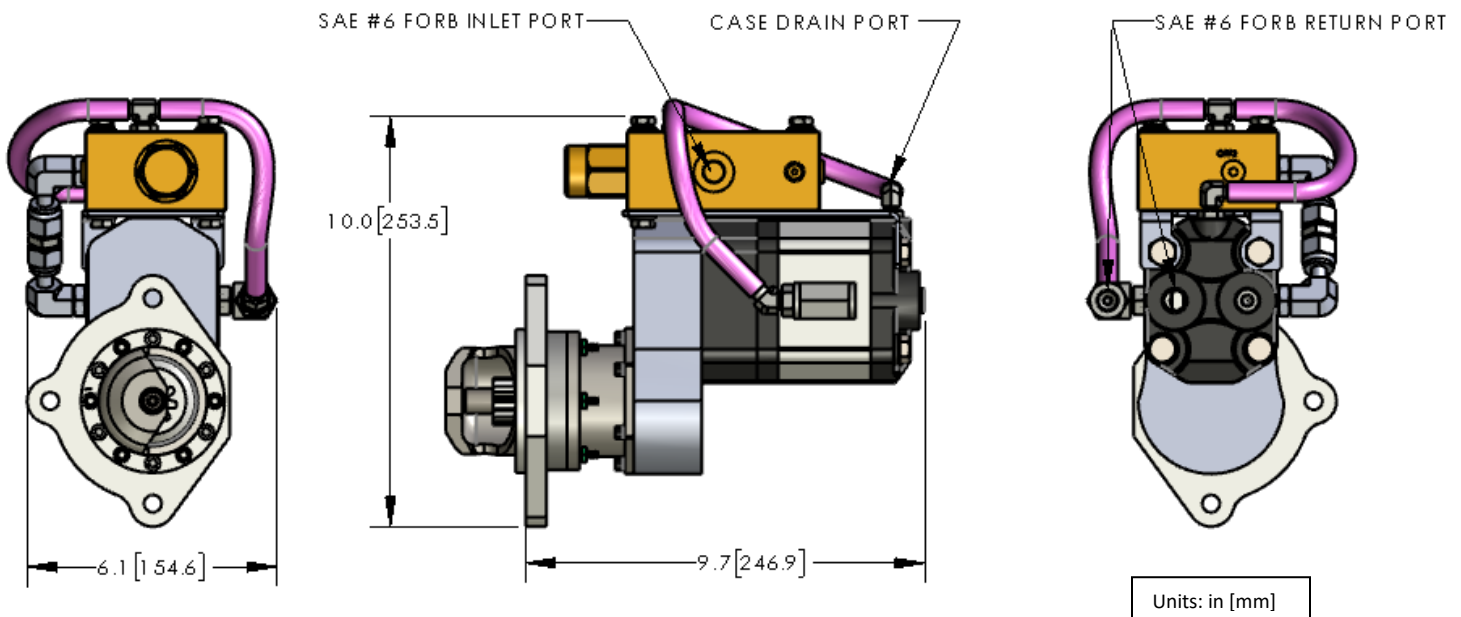
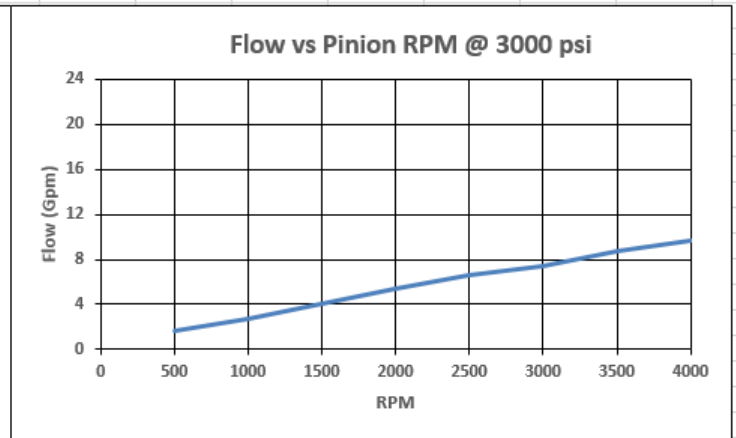
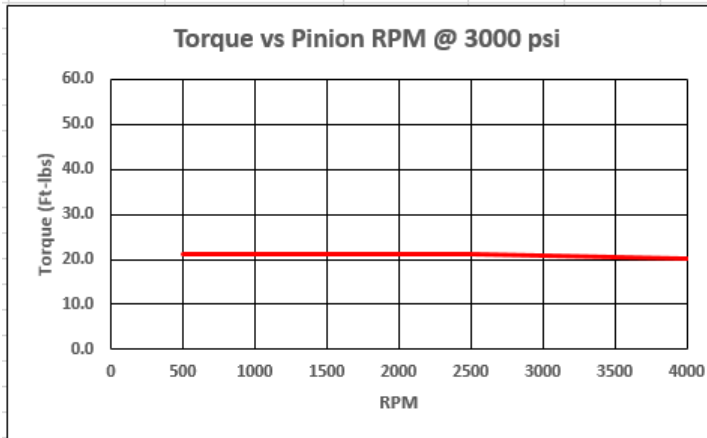

Note: Case Drain must be vented to the tank or return line