

POW-R-QUIK

ENGINE STARTING SYSTEMS

Hydraulic Starters for Fracturing Applications

HSCV series product is the most advanced Engine Hydraulic Starter in the industry featuring the Integrated Smart Valve (Patent No: US 9,360,025 B2)

- ✓ Universal for large engines (CAT, Cummins, MTU)
- ✓ Built-in safety against operator errors
- ✓ Starts reliably any engine at any temperature
- ✓ Protects the engine ring gear by pre-engaging the pinion, completely eliminating the shock load of a typical hydraulic starter
- ✓ Best warranty in industry - 18 months

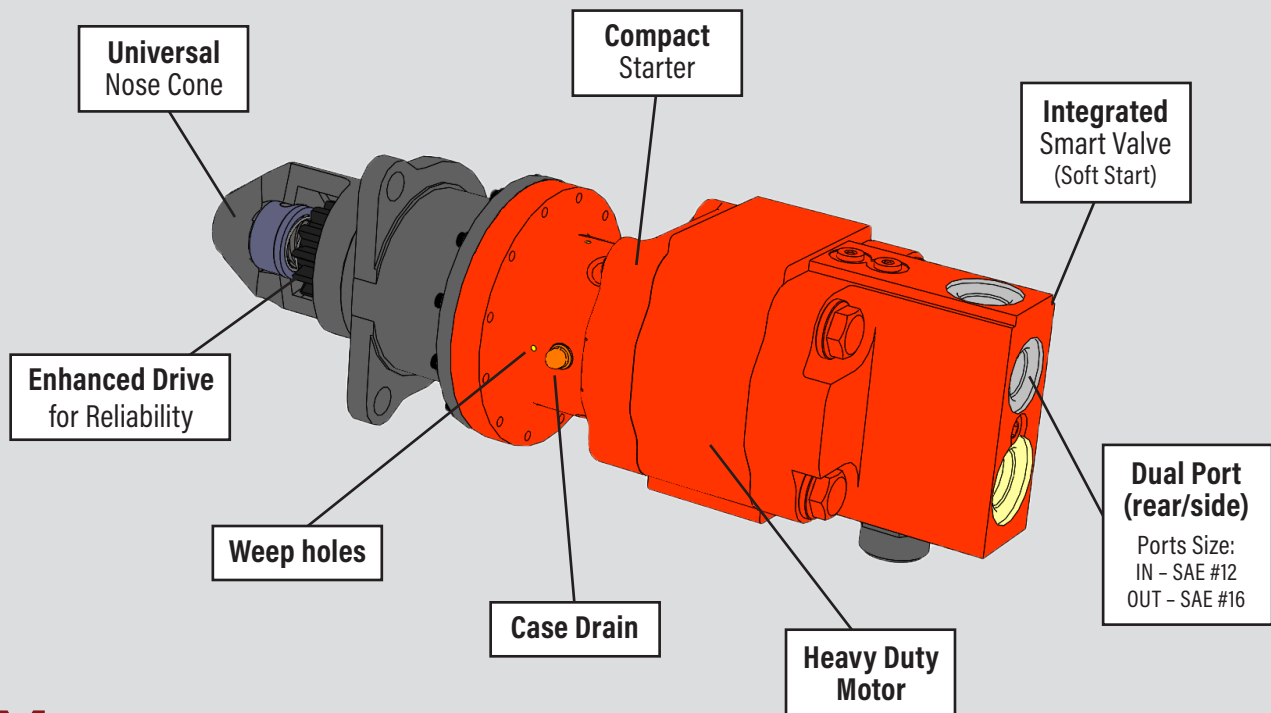
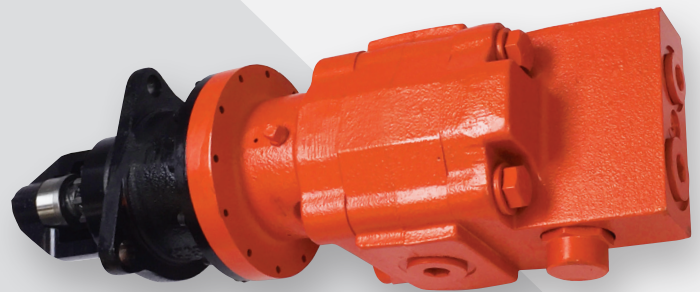

POW-R-QUIK

ENGINE STARTING SYSTEMS

Hydraulic Starters for Fracturing Applications

Starter Technical Specifications - HSCV 360

Engine displacement: 45L and above

Torque output: max. 198 FT-LBS

Pinion: 6/8 DP - 12 T

Rotation: Right Hand

Pressure: 1500-3000 PSI

Flow : 40-60 GPM

Temperature: -40° to 180° F

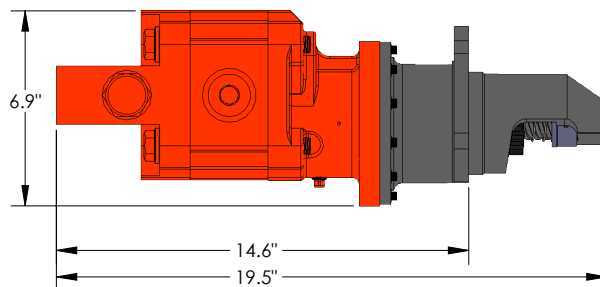

Factory Assembled ON/OFF (Rear Port)

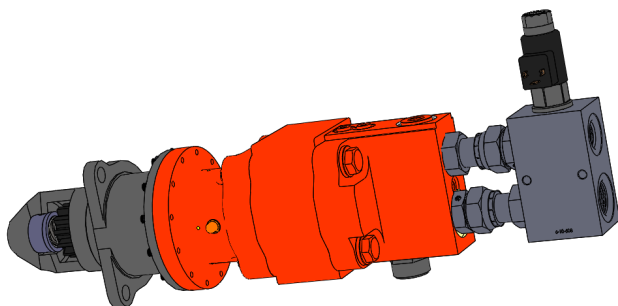

ON/OFF Valve with Manual Override

Coil Voltage: 12V or 24V

Max. Power 22W

Connector Form A, 3 Pin

Max Flow: 60 GPM

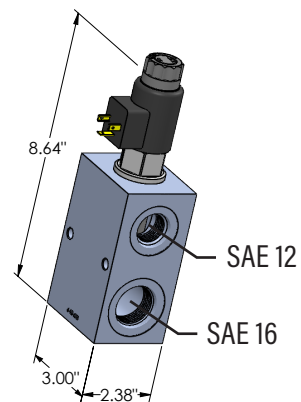

4540 West 160th St, Cleveland, OH 44135

800.537.7444 / 216.404.7112

sales@powrquik.com